Installation & Maintenance



MINERAL INSULATED
HEATER CABLE

CONTENTS

GENERAL INFORMATION	3
PRODUCT SELECTION.....	3
RECEIPT & STORAGE	3
PIPE LENGTH VERIFICATION	3
DRAWINGS	4
INSTALLATION.....	4
HEATER CABLE CONSTRUCTION	5
HIGH TEMPERATURE & WATTAGE INSTALLATIONS.....	8
HEATER CABLE ATTACHMENT.....	10
HEAT SINK INSTALLATION	10
PUMPS.....	12
INSTRUMENTATION.....	14
THERMAL INSULATION.....	14
ELECTRICAL CONNECTIONS	15
ELECTRICAL REQUIREMENTS.....	16
TESTING	16
START-UP.....	19
OPERATION & MAINTENANCE.....	19
TROUBLESHOOTING	21

GENERAL INFORMATION

This manual is designed for use with Nelson Mineral Insulated Heater Products. For applications not specifically addressed, please contact your local representative.

How Heating Systems Work

An electric heating cable system uses the electric heater cable to replace the heat that is lost through the thermal insulation system. Replacing the lost heat allows the pipe and product inside the pipe to be kept at a constant temperature. This will keep water from freezing and bursting a pipe, or a liquid from setting up and plugging the pipe. Simple systems may turn the entire system on with a contactor or switch, while others will use a thermostat with each heater cable to control the temperature for each pipe separately.

PRODUCT SELECTION

Check and verify that the proper heaters are being installed on each pipe and vessel. If no design/installation documents exist, check Nelson's Design and Selection Guides to determine the proper equipment for the application.

RECEIPT & STORAGE

Receipt

- Compare the materials against the shipping bill to verify receipt of proper materials.
- Inspect heater cable and components for transit damage. Insulation resistance tests on each cable set is recommended. Use at least 500VDC although 1000VDC megger test voltage is recommended. Insulation resistance should be 20 megohms minimum.
- If design documents (line lists or per circuit bills of material) exist, check the materials received against the lists to verify receipt of all needed materials, If no design documents exists, keep a receipt of all materials received.

Storage

Cables and system components should be stored in a clean, dry area. The equipment should be protected from mechanical damage during storage.

Withdrawal from Storage

It is recommended that a check-out record be kept (in conjunction with the receipt records) on equipment as it is removed from storage. This will serve to identify developing material shortages before they happen - since project additions can cause the use of material for other than designated piping.

PIPE LENGTH VERIFICATION

Each heater cable is factory fabricated for a specific length of a certain size of pipe, and may be used in conjunction with certain other series wired cables. The cables are not interchangeable and the system will not operate properly if cable segments are not installed on the correct pipes. The pipe lengths must be determined before the heater cable circuit can be designed. There are two standard methods of pipe lengths verification:

- Field measurements, where the actual piping is measured to determine the correct length.
- The second method is usually less accurate and it involves dimensioning from construction drawings. To use this method the field installation must closely follow the construction drawings. A 5% adder, not to exceed 5 feet can be added to each cable to help absorb variations. Any cable overage can be absorbed at heat sinks. Any deviations should be reviewed by the system designer.

In both of these methods all heat sinks (pipe supports, valves, hangers, wall penetrations, etc.) must be noted, since they will require additional heat.

DRAWINGS

On engineered systems, drawings for all individual electric trace circuits may be provided for installation of heat tracing. An electric trace circuit number, a segment number, and a catalog number is assigned to each cable for identification purposes. Each installation drawing will have a complete bill of material, including cables, temperature controller, junction boxes, strapping material and electrical parameters.

The electrical parameters include a note to verify the circuit wiring - normally series connected.

INSTALLATION

WARNINGS:

While there are many acceptable ways of installing Nelson's electric heating equipment, certain actions can be dangerous to personnel and your installations. Please take care to avoid the following problems:

- **ENSURE CABLE IS PROPERLY SECURED TO PIPE.** See section on heater cable attachment for more details.
- **INSTALL CABLE SO MINIMAL RE-BENDING IS REQUIRED TO SERVICE EQUIPMENT.** Cable will work harden and break if repeatedly re-bent. Pumps, valves, strainers, etc. should be traced in a manner to allow the cable to be moved away with minimal bending.
- **HEATER CABLE SETS CANNOT BE RANDOMLY SWITCHED.** Each cable is designed for a specific wattage, pipe size, length, and maintenance temperature. Cables may not work in a different situation. Changes should be reviewed for design adequacy.
- **DO NOT OVERLAP HEATER CABLES.** Overlapped contact points will produce hotter spots that could exceed ignition temperatures and/or overheat cable/pipe.
- **DO NOT BEND THE HEATER CABLE WITHIN 76.2mm (3") OF FITTINGS.** Fitting joints could be damaged.
- **DO NOT BEND THE HEATER CABLE TO AN INSIDE RADIUS OF LESS THAN FIVE TIMES THE CABLE'S DIAMETER.** This will damage the cable.
- **HEATER CABLES FOR HAZARDOUS CLASSIFIED AREAS SHOULD BE TAGGED AS BEING CERTIFIED FOR A SPECIFIC AREA.** Sheath temperatures are controlled by design. Be sure the cable is designed for the proper temperature limits.
- **HAZARDOUS (CLASSIFIED) AREA (EXPLOSIVE DUST OR GAS) REQUIRE THE USE OF SPECIAL CONTROLS AND COMPONENTS.** Any area having explosive gases, (such as chemical or petrochemical installations), or explosive dust (such as coal handling or granaries), require connection components and controls that are approved for use in these areas. Installation of non-approved heaters can result in a fire or explosion.
- **LEAVE ALL TAGS ON THE CABLE.** They contain electrical, approval, and further installation information.
- **BOND THE METAL SHEATH OF THIS TRACE HEATER TO SUITABLE EARTH / GROUND TERMINAL.**
- **TERMINAL ENCLOSURES MUST BE UL LISTED OR CLASSIFIED** for the appropriate classes and groups when used in Class I, Division 1; Class II, Division 1 Hazardous locations and certified as flameproof when installed in Europe.
- **Minimum installation temperature -40°C (-40°F)**

Scheduling

Pressure testing of the pipe and installation of the instruments should be completed prior to the start of the heater cable installation. The installation of the electric heat tracing needs to be coordinated with the piping, insulation, electrical and instrument groups. It should begin only after mechanical construction is completed.

Pre-Installation Check

Walk the piping system and plan the routing of the heater cable. Use this check to verify completion of instrumentation and mechanical work. All coatings (paint, etc.) must be dry before attempting the heater cable installation.

Heater Handling

- ❑ When handling the heater cable, avoid pulling it over or installing against sharp edges.
- ❑ Do not kink or crush the heater cable; including walking on or driving over it with equipment.
- ❑ Unroll heater cable adjacent to the pipe to be traced, starting at the power connection end of the circuit.
- ❑ Keep the cable strung loosely, but close to the pipe being traced. This will avoid interference with supports and other equipment.
- ❑ Attach cable to the pipe at both ends of the circuit and work toward the middle.
- ❑ **Additional heater cable is required on valves, pipe supports and other equipment.** See *Section 10 (Heat Sink Installation)* for exact lengths and method of installation.
- ❑ Make a loop with the required cable length at each heat sink. Looped lengths can be slightly adjusted to ensure a proper cable fit along the pipe.
- ❑ Shape loops against heat sink in a manner that will allow easy removal. See *Section 10*.

Heater Cable Location on Pipe

The heater cable should be installed at ten o'clock, two o'clock, four o'clock or eight o'clock positions. This helps prevent physical damage to the heater cable from falling objects and being walked on. See *Figure 1* below.

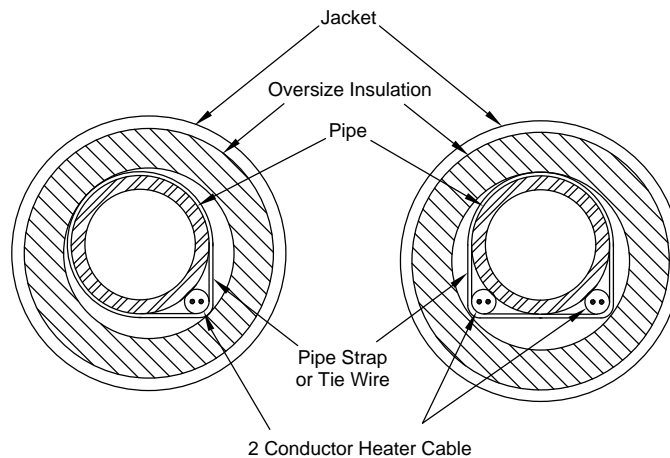

Figure 1
Installation of Heater Cable on a
Single Trace and Double Traced Pipe

HEATER CABLE CONSTRUCTION

General

The heater cable will be type MI, single or two conductor resistance element, insulated with magnesium oxide, and covered with a metallic sheath. The metallic sheath is Alloy 825, which may be used to 593°C (1100°F). The cable type, lengths of hot and cold sections, and cable form can be determined from the Nelson catalog number. See *Table I*.

Table I
Cable Catalog Numbering System

*	A	752K	100	07
Special Features	Form A or E (See Table II)	Cable type hot section See 308-AS-001	Hot section length in feet	Cold section length in feet
PREFIX	SUFFIX	DESCRIPTION		
P		Pulling Eye for "A" form only		
X		Oversized cold section or special feature		
	EM	Mounting of hot-cold junction outside thermal insulation (freeze protection of lines over 316°C (600°F))		
	QT	Factory mounting of QHT-3 Adapter (High wattage and/or maintain temperature)		
	UG	UL listing tag**		
	UH	UL hazardous listing tag**		
	FH	FM hazardous listing tag**		
	CH	CSA hazardous listing tag**		
	CHB	CSA Group B hazardous listing tag**		
	UM	UL snow melting listing tag**		
** Requires volts, amps, and watts with each cable ordered.				

It is recommended that all heater cables be tagged with a discrete circuit number when they are built. This will facilitate identification, components needed and electrical wiring during installation.

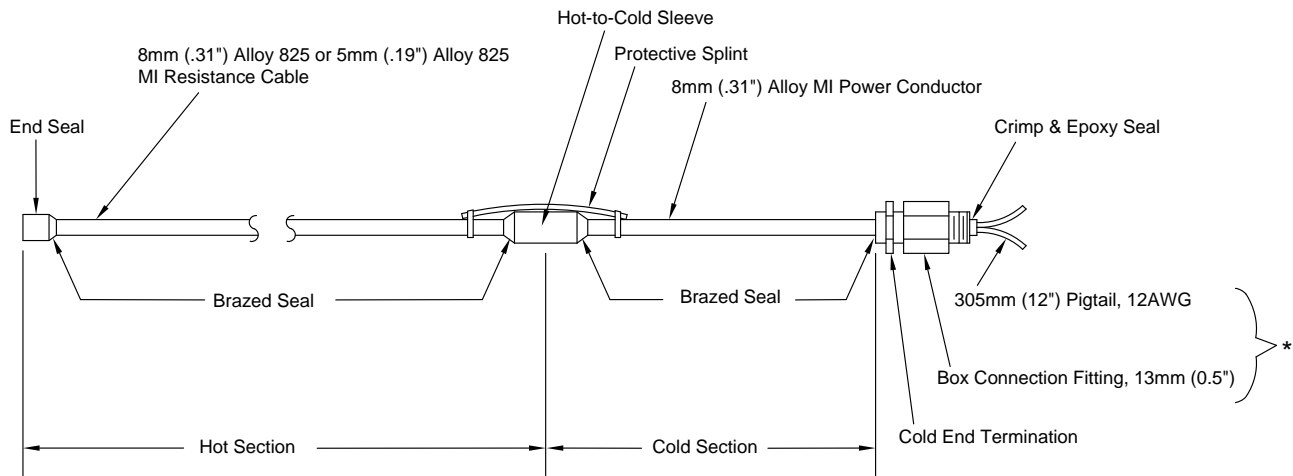

*Recommended torque for ferrule
Gland Nut: 40 FT. LBS. for the 21.3mm (1/2NPT)
60 FT. LBS. for the 26.7mm (3/4NPT)

Figure 2
Heater Cable Configuration

Table II
Heater Unit Forms

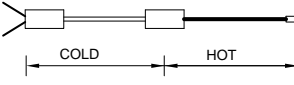
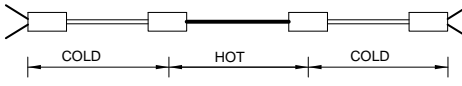
Form	Diagram
A	
E	

Factory assembled heater cables consist of heating sections, cold section, box connector, and 305mm (12") long insulated leads.

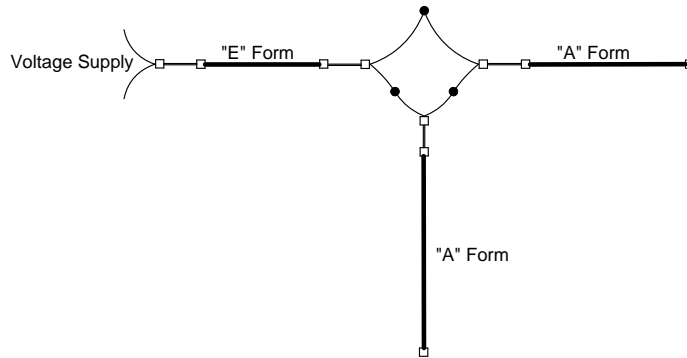

Figure 3
Use of "A" & "E" Form Cables in Single Trace Application
(2 Conductor Cable)

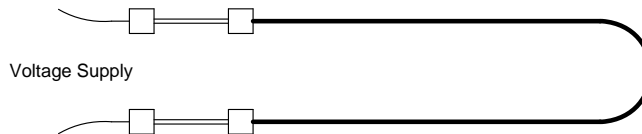

Figure 4
Use of "E" Form Cable on Multiple Trace Application
(1 Conductor Cable)

NOTE: Length of heating cable must be double the actual pipe length (double traced) to provide an electrical path.

HIGH TEMPERATURE & WATTAGE INSTALLATIONS

The cold lead and hot-cold junction have copper wire in them. This copper has to be kept below 315°C (600°F) to prevent deterioration of the conductors. The junction and cold lead mounting is changed, based on the application temperatures and cable wattage.

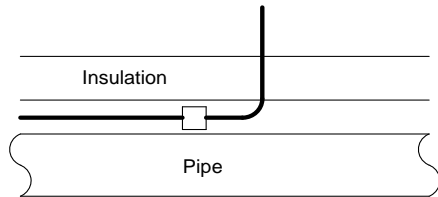

Figure 5
Regular Cable

Standard

- Conductor temp below 316°C (600°F).
- Process maintenance under 149°C (300°F).

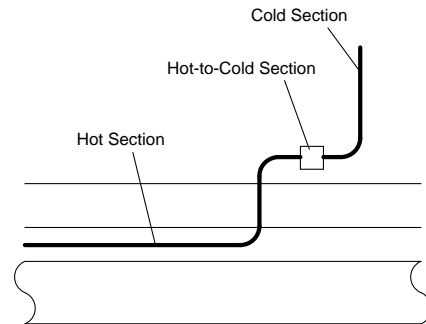

Figure 6
EM Suffix

High Temp/Low Wattage

- Wattage below 65w/m (20w/ft).
- Steam piping freeze protection

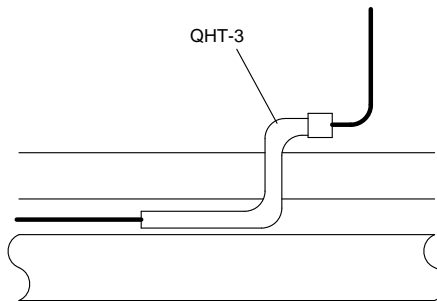

Figure 7
(QT Suffix or QHT-3)

High Temp/High Wattage

- Wattage above 65w/m (20w/ft).
- Process maintain over 149°C (300°F)

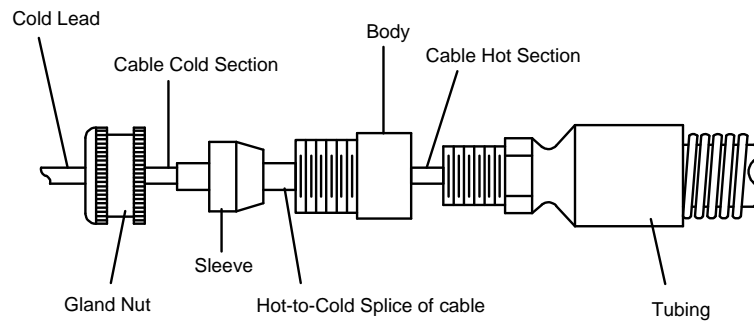

Figure 8
QHT-3 Attachment to
Heater Cable

ASSEMBLY INSTRUCTIONS:

1. Install heater cable, but do not fasten last two feet of the hot section to the pipe.
2. Slip the unthreaded end of the tubing over the cold section of cable. Slide tubing down past the hot-to-cold fitting.
3. Slip the body, sleeve, and gland nut over the cold section of cable in order given. Align sleeve as shown above.
4. Position sleeve about 6mm (.25") from the cold section end of the hot-to-cold fitting.
5. Tighten body to tubing.
6. Position sleeve and attach to the gland nut. Apply sufficient pressure to snug lead sleeve onto hot-to-cold fitting.
7. Tie down last 152mm (6") of tubing on pipe with tie wire.
8. Form tubing to shape desired to exit insulation. The hot-to-cold fitting should be outside the insulation.

Junction installed out side insulation.

Offset hot-cold junction from pipe to allow thermal insulation to be installed between pipe and junction.

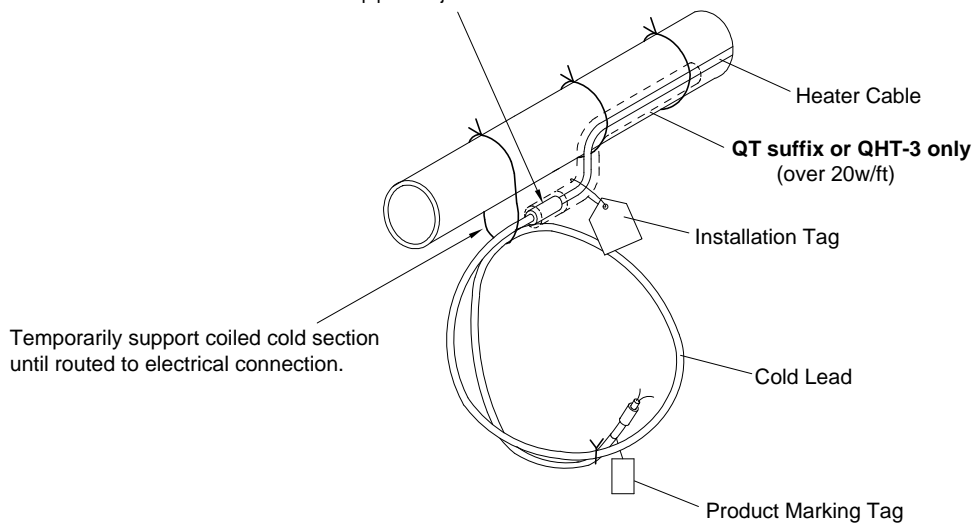

Figure 9
High Temp Cable Junction Installation
Suffix QT or EM

HEATER CABLE ATTACHMENT

Heater cable shall be fastened to the piping with stainless steel straps or tie wire. Steel straps or tie wire shall be installed with approx. 305mm (12") spacing as shown in **Figure 10** below. Stainless steel straps or tie wire should be used to secure heater cable to pipe and irregular shaped objects such as valves, etc. Cable should be loosely attached to allow for expansion and contraction without work hardening during thermal cycling of the heater.

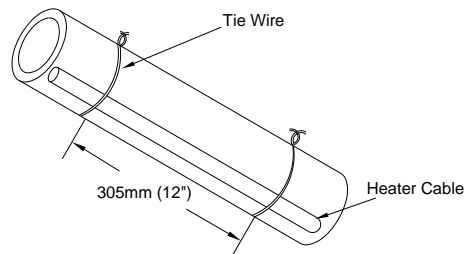

Figure 10

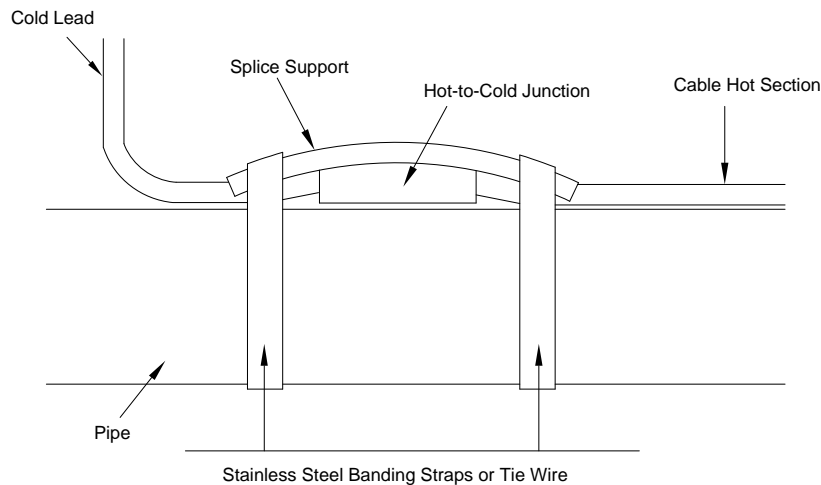

Figure 11
Mounting of Hot-Cold Junction

HEAT SINK INSTALLATION

Extra heater cable is required at all heat sinks. Heater cables should be applied in a manner to facilitate the easy removal of valves and small in-line devices without the removal of excessive thermal insulation or having to cut the cable. The best way to accomplish this is to loop the heater. The amount of heater cable installed on each valve, hanger, etc. varies with the pipe size and type of device. **Table III** gives the correct additional cable to be installed on each device.

The following figures show installation details for various typical situations. **Figures 12 & 13** show the area of the pipe that is affected by heat losses from items penetrating the insulation such as supports, hangers, valve yokes, etc. Heater cable adders can be applied anywhere in this area to compensate for these heat losses. Refer to **Table III** for proper footage of cable adder required.

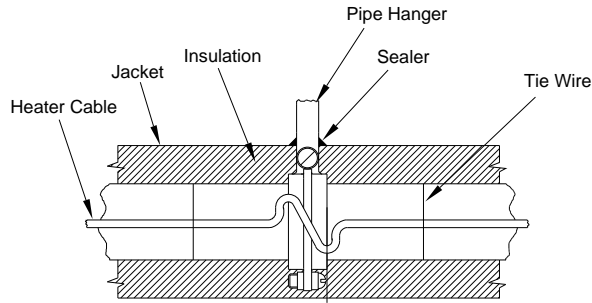

Figure 12
Hanger

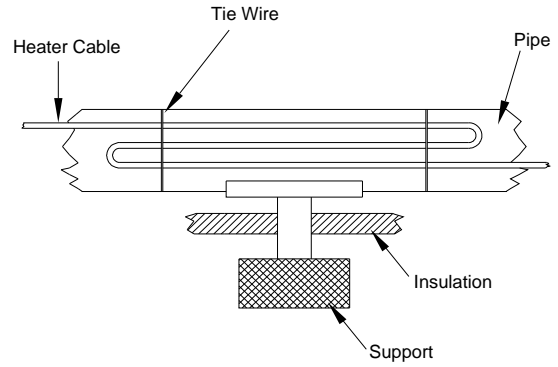

Figure 13
Support

ASSEMBLY NOTES:

1. For cable length at hanger and support, refer to Table III.
2. Exact configuration may vary.
3. Fully insulate and weather-seal.

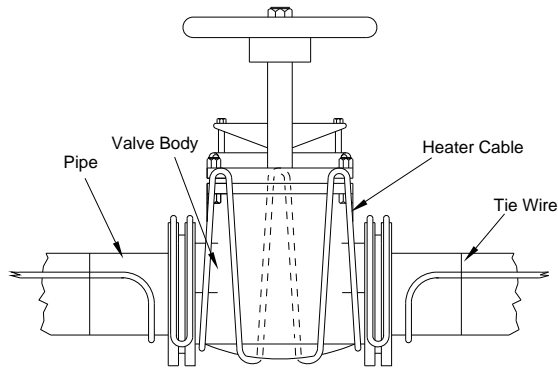

Figure 14
Flange valve

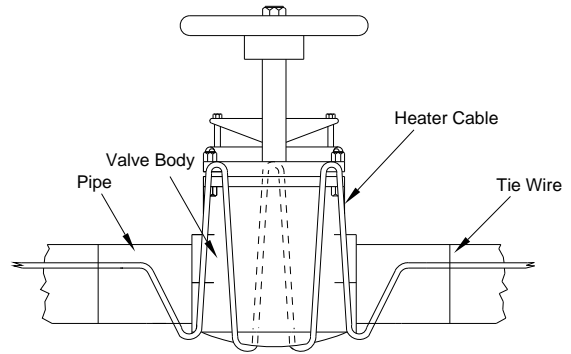

Figure 15
Screw or Welded Valve

ASSEMBLY NOTES:

1. Exact configuration may vary per valve type.
2. For removable valve bodies, leave a loop of tracing of the proper length when tracing the pipe. Then trace the valve so that it can be serviced without cutting the heater.
3. For correct amount of tracing per valve type, refer to *Table III*.
4. Secure cable with tie wire criss-crossed over valve body.
5. Take care to keep the heater in as good physical contact with the valve body as possible.
6. Fully insulate and weather-seal.

ASSEMBLY NOTES:

1. For cable length at flange, refer to *Table III*.
2. Exact configuration may vary.
3. Fully insulate and weather-seal.

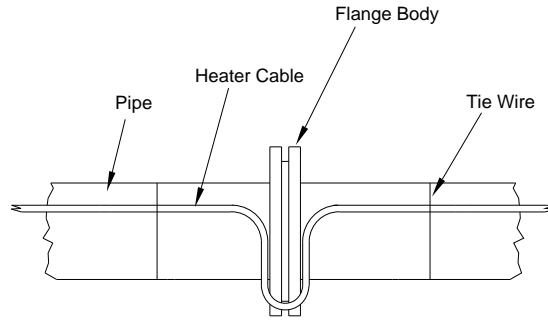

Figure 16

Table III
Heat Loss Adder

Pipe Size	Pipe Fitting Type				
	Flange Pair	Vent & Drain	Pipe Support	Globe, Ball & Butterfly Valves	Gate Valve
.50	.30	1.0	1.0	1.0	1.0
.75	.30	1.0	1.5	1.0	1.5
1.00	.30	1.0	1.5	1.0	2.0
1.50	.30	1.0	2.0	1.5	2.5
2.00	.30	1.0	2.0	2.0	2.5
3.00	.30	1.0	2.0	2.5	3.0
4.00	.50	1.0	2.5	3.0	4.0
6.00	.80	1.0	2.5	3.5	5.0
8.00	.80	1.0	2.5	4.0	7.0
10.00	.80	1.0	2.5	4.5	8.0
12.00	.80	1.0	3.0	5.0	9.0
14.00	1.0	1.0	3.0	5.5	10.0
16.00	1.0	1.0	3.5	6.0	11.0
18.00	1.0	1.0	3.5	7.0	12.0
20.00	1.0	1.0	3.5	7.5	13.0
24.00	1.0	1.75	4.0	8.0	15.0

NOTES:

1. Nominal pipe length in feet.
2. Adders are for various in-line fittings to compensate for areas of greater heat loss.
3. Values above are based on area average of various fittings available, with the assumption that fitting insulation will be equivalent to pipe insulation. The nominal length of tracer to be applied to a particular fitting would be the value shown in this chart plus the flange-to-flange length of the fitting.

PUMPS

All pumps should be heat traced when suction and discharge lines are heat traced. Pumps should be heat traced with a separate cable. Each pump shall be traced in a manner, see *Figures 17 & 18*, that will allow the cable to be moved away from the pump for servicing or removal. The cables should be pulled away from the pump without kinking the cable. Remove with care so that cable may be replaced in its original condition. If pumps require frequent maintenance, then removable insulated enclosures with heaters attached to the enclosure are recommended.

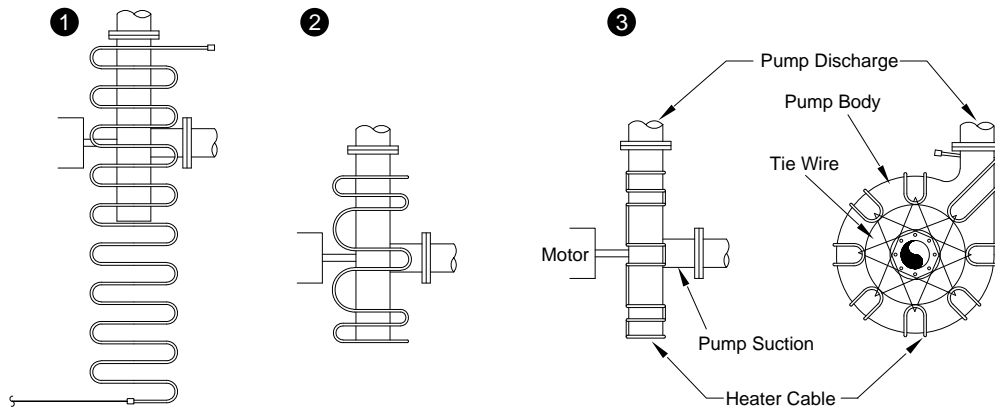

Figure 17
Centrifugal Pump

ASSEMBLY NOTES:

1. Pre-bend loops to fit over the edges of the pump, a minimum of 100mm (4"), before installing.
2. Mount on pump, adjusting spacing between loops to cover pump body.
3. Use tie wire or aluminum tape to hold cable in place on pump. See step 3.
4. Pump must be fully insulated and weather-sealed.
5. Heater length required for pump application will vary with pump size - contact your Nelson representative or the factory for details.

ASSEMBLY NOTES:

1. Determine the width of the pump to be traced.
2. Pre-bend the heater cable starting with the end of the hot section and bend it approximately at the distance as shown below.
3. Continue to make these "S" bends until the whole hot section has been bent.

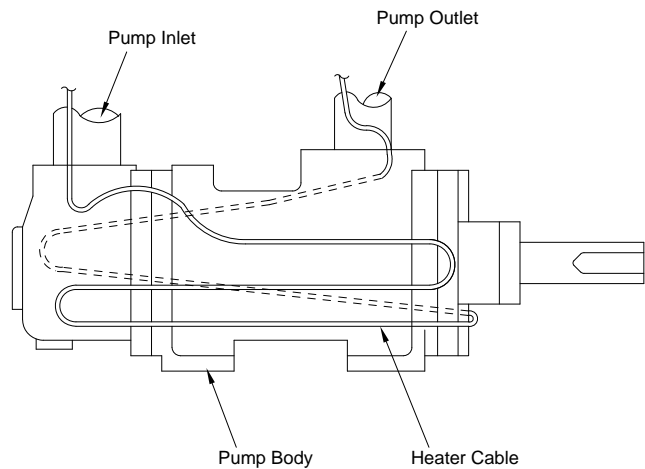

Figure 18
Pump

INSTRUMENTATION

Instrument lines and their associated instruments shall be traced. Any supports or other heat sinks shall have additional cable serpentine on the object, or if space will not allow, then put the extra cable on the tubing in the area of the heat sink. A separate thermostat should control long runs of instrument lines if the system is process control tracing. The instrument itself should be traced if fluid is in the instrument body. See **Figures 19 & 20** for typical instrument tracing details.

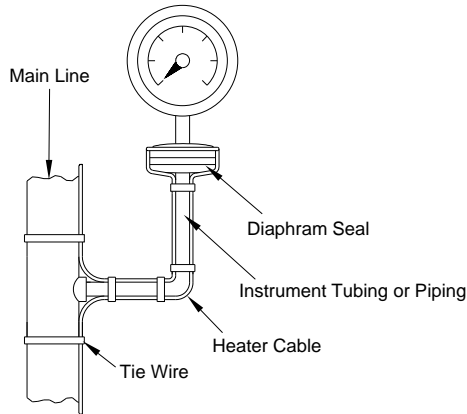

Figure 19
Pressure Indicator

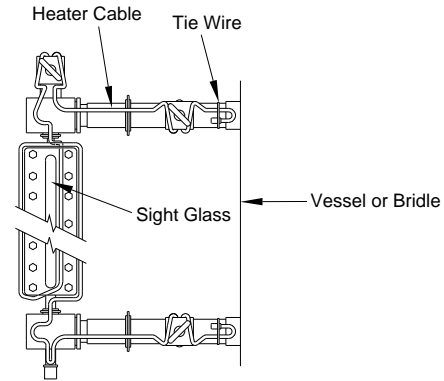

Figure 20
Level Gauge

THERMAL INSULATION

Pre-Insulation Checks

Inspect the heater cable and components for correct installation and possible damage. In particular, verify that:

- Heater is not on the top of the pipe and is installed flat against the pipe.
- The proper extra amount of heater cable has been installed at each valve, flange, pipe support, etc., and that it is free from physical nicks, tears, or gouging.

Installation

- The proper selection and installation of pipe insulation is essential for good performance of a heat tracing system.
- Rigid insulation should be oversized (min.13mm (0.5")), or the next larger pipe size to accommodate the heater installation.
- Check the thermal insulation type and thickness against the design criteria. Changes in insulation type or thickness may require a different wattage heater cable.
- Long vertical runs of oversized pipe insulation will experience temperature piling (heated air circulating upward). This can be reduced by installing air baffles at approx. 3m (10') intervals. See **Figure 21**.

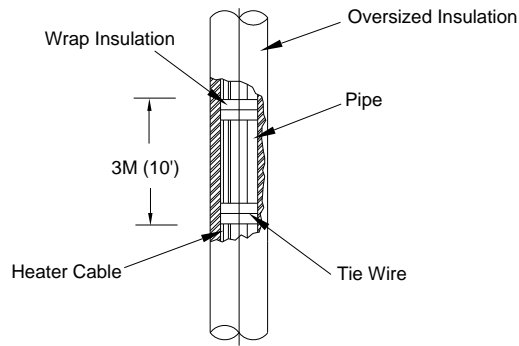

Figure 21
Baffle for Oversized Insulation

- Whenever blown on or muddied insulation is used, the cable should be covered with some type of foil after it is attached to the pipe, valve, pump, etc., to prevent thermal isolation of heating element.
- Leaks at valves, flanges or pumps should be repaired and the insulation dried.
- Verify that all pipe work, including wall penetrations, fittings, etc., has been completely insulated.
- Insulation must not be wet from rainfall prior to the application of waterproofing. *See warning below.*

⚠ WARNING:

All thermal insulation must be dry for the proper functioning of the heat trace system.

- Lap joints on vertical piping must be properly overlapped - higher piece lapped over the top of lower piece.
- Band seals must be used at lap joints to prevent the ingress of water.
- All penetrations of the lagging (valve stems, hanger rods, etc.) must be properly waterproofed.
- Irregular shaped items (pumps, etc.) must be properly waterproofed.
- Wet pipe insulation has poor thermal insulating capabilities (which will result in line freeze-up). It will also cause electrolysis & corrosion.
- It is recommended that another insulation resistance (megger) test be done after the insulation has been installed to verify that the heating cable was not damaged during the insulation installation.

NOTE: *To minimize potential damage to the heater cable, install the insulation as soon as possible.*

Marking

Install "Electric Trace" signs on alternating sides of the piping at 3-6 meters (10-20 feet) intervals as a warning to maintenance personnel.

ELECTRICAL CONNECTIONS

Moisture inside the electrical connection enclosure will cause both corrosion and electrical shorting problems. The potential for this type of problem can be greatly reduced by:

- Low point conduit drains - condensation from conduit can fill small enclosures.
- Proper sealing of all enclosure openings.
- Bottom conduit entry into enclosures.
- Keeping conduit fittings/pull box covers closed at all times.
- Keeping enclosure covers closed and secured as much as possible during installation sequence.

- Proper closing and sealing of enclosure covers to prevent leaking into the housing.
- Use of a moisture proofing/electrical spray sealant on the thermostat and electrical connections (including all metal parts) at completion of installation.

ELECTRICAL REQUIREMENTS

Voltage Rating

Verify that the heater cable voltage rating is suitable for the service used. Voltage and wattage ratings are printed on the cable tag.

Electrical Loading

Size over-current protective devices according to National Electric Code. If devices are other than standard thermal magnetic circuit breakers, consult factory.

Voltage Surge Protection

Surge protection should be installed at the breaker panel if the panel is not isolated from its 600v/480v supply by an isolation transformer.

Ground Fault Protection

Ground fault circuit breakers are required on all heater applications per the National Electric Code - check code for proper circuit breaker protection. Typically, 30 ma trip devices are required due to the capacitive leakage of the heater cable and it's associated power wiring.

Waterproofing

Moisture penetration of the electric system is the single largest source of problems in a heater cable system installation. Therefore, particular care must be given to the proper sealing of all electrical connections. All electrical connections (heater to power wiring, thermostat connections, panel and breaker connections, etc.) should be sealed or moisture proofed in some fashion. *See warning below.*

WARNING:

Nuisance tripping of ground fault circuit breakers will occur unless all electrical connections are waterproofed

TESTING

Recommendations

Electrical tests are recommended at specific points on the receipt and installation of heater cable. This periodic testing is designed to prevent the expenditure of wasted labor in the event of damage to the product. Installation costs of the cable and thermal insulation are much greater than the heater cable. Quick identification of any heater cable damage is the most economic approach to an installation. An insulation resistance test is recommended at the following points of the installation process:

- UPON RECEIPT of the heater cable
- BEFORE thermal INSULATION installation
- IMMEDIATELY AFTER thermal INSULATION installation
- As part of a PERIODIC MAINTENANCE program

Procedure

The insulation resistance test is used to check for damage to heater jackets. Connections for the megger are made as shown in **Figure 22** to the pigtail wires & the metal sheath. Test should use at least a 500VDC megger, however, a 1000VDC megger test is recommended. Minimum acceptable readings should be 20 megohms per cable.

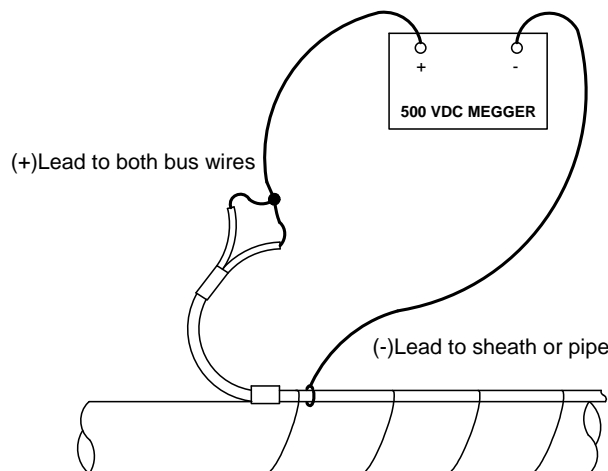

Figure 22

A record should be kept of the readings taken from the time the cable is first installed on the pipe. A history of the insulation resistance reading can be helpful in spotting moisture ingress into the electrical system (by seeing a gradual decline in the insulation resistance) or physical damage to the heating cable (sharp decline in the insulation resistance). A sample record form is shown in **Figure 23**.

The Periodic Inspection Record Form may be used in one of two ways:

- One sheet per circuit. The results of periodic tests of a single circuit are posted in vertical columns, beginning on the left and working toward the right. This allows easy comparison of test values for up to seven test sequences on an individual circuit.
- On circuit per column. Test data for a single test sequence on as many as seven circuits can be recorded on a single sheet.



Pipe Number
Circuit Number
Heater Cat. No.
Circuit Length

PERIODIC INSPECTION RECORD

Freeze Protection Circuits -							
Perform these checks as season requiring use approaches.							
Temperature Maintenance Circuits -							
Perform these checks at least twice per year.							
Maintenance Checks							
Visual inspection inside connection box for corrosion, moisture, etc.	Initial						
	Date						
Damage or cracks (leaks) in insulation seals at valves, hangers pumps, etc.	Initial						
	Date						
Heating cable properly connected and grounded.	Initial						
	Date						
Thermostat checked for moisture, corrosion, set point, switch operation, and capillary damage.	Set Point						
	Initial						
	Date						
Megger tests performed at power connection, with both lead wires disconnected from power wiring.	Reading						
	Initial						
	Date						
Circuit voltage at power connection.	Reading						
Circuit amperage after 5 minutes	Reading						
Insure removable blankets are installed properly and all air gaps are sealed.	Reading						
Watts/Ft. <u>Volts x Amps = w/ft.</u> feet	Initial						
	Date						
All connections, boxes, and thermostats have been resealed.	Initial						
	Date						
REMARKS & COMMENTS							

Figure 23
Periodic Inspection Record

START-UP

Heat-Up Time

Heat-up capacity (the ability to heat the pipe and it's contents rapidly) is not normally designed into the system. Cold start-ups should allow adequate time for the pipe to come up to temperature.

OPERATION & MAINTENANCE

System Design Installation & Documentation

The heating cable system must be properly designed, installed and documented. This documentation should at least include line lists and location identification documentation. As-built installation drawings provide the optimum maintenance tool. Test records should also be considered as part of the system documentation requirements.

Preventive Maintenance

A preventive maintenance program is needed which will encompass both visual and electrical checks of the system. These should be done not only before initial operation of the system, but also after any maintenance has been performed.

Periodic Inspections

- Thermal insulation - check weatherproofing for damage, missing seals, cracks, or gaps in caulking and mastic coatings, damaged, or missing lagging. When damage does exist, the insulation will need to be repaired or replaced, and then re-sealed. **WET INSULATION HAS POOR INSULATING PROPERTIES, THEREFORE THE INSULATION MUST BE KEPT DRY.** If insulation has been damaged, check the heater cable for damage -- replace any damaged sections.
- Inspect junction boxes, connection boxes, and thermostats for corrosion, moisture or foreign matter.
- Check tightness of electrical connections, proper electrical insulation of heating cable wires, adequacy of moisture seal on electrical connections.
- Check all thermostat capillaries to insure they are shielded from physical damage and secured properly to pipe.
- Verify that all thermostat power and probe leads are securely connected and on the correct terminal.
- Verify all enclosure, connection box, etc., covers are property closed and that the thermostat is switching on & off by rotating knob set point back and forth, and on by measuring current flow in the circuit when the unit switches on. Reset the knob to the proper temperature after completion of the test.

Frequency

Inspections should be made prior to the start of the freeze season on freeze protection systems. Process maintenance systems should be checked on a frequent basis, at least twice a year.

Personnel Training

Qualified maintenance personnel must be used to maintain the system. It is recommended that periodic training programs be utilized to assist in keeping maintenance personnel up to date on equipment and procedures.

Maintenance

The heater cables will not require any maintenance, unless damaged. Mechanical temperature controls should have dial stem lubricated and be sprayed with a moisture repellent/corrosion inhibitor once a year on all metal parts. Disconnect the electrical connection for the heater cable and protect it from mechanical or thermal damage during any repair of the piping system. Check the heater cable installation after any piping system repairs per established procedures. Replace and water seal the thermal insulation system.

Damaged Products

Replace the damaged cable immediately. Moisture migration into the good section of the cable may cause electrical shorting in that cable after repair of the damaged section.

TROUBLESHOOTING

SYMPTOMS	PROBABLE CAUSE	CORRECTION
A. Circuit Breaker Trips (Standard)	<ol style="list-style-type: none"> 1. Circuit breaker undersized 2. Circuit oversized 3. Start-up at too low temperature 4. Defective circuit breaker 5. Wiring connections may be shorting out. 6. Physical damage to the cable may be causing a short. 7. Thermostat 	<ol style="list-style-type: none"> 1, 2, 3 Determine total current load and resize the breakers. Verify that power wire size is compatible with larger size breaker. 4. Replace circuit breaker. 5. Locate and repair faulty connections. Megger per installation instructions. 6. Locate and repair damaged sections of heater.* Megger per installation instructions. 7. Check for proper wiring.
B. Circuit Breaker Trips (Ground Leakage Type)	<ol style="list-style-type: none"> 1. All of section A. 2. Excessive moisture in connection boxes. 3. Nick or cut in heater or power feed wire with moisture present. 	<ol style="list-style-type: none"> 1. All of section A. 2. Dry out and seal connections. Megger per Installation Instructions (20 megohms min.) 3. Locate and repair or replace damaged heater or power wire.*

*To locate shorting problems, follow these steps:

1. Visually inspect the power connections for proper installation.
2. Check around the valves, pumps, and any area where there may have been maintenance work done, for visual indications of damage.
3. Look for crushed or damaged insulation lagging along the pipe.
4. Inspect heater cable under the thermal insulation.
5. If you have not located the problem by now, you will have to isolate one section of heater cable at a time until you determine the general area of damage. First, isolate by disconnecting any series or parallel wired cable sets, and megger each cable. Remove cold section from heating section and megger each. For long runs of cable, it may be necessary to cut the cable in half to isolate the shorted heating section.

SYMPTOMS	PROBABLE CAUSE	CORRECTION
<p>C. Power output is zero or lower than rated.**</p>	<ol style="list-style-type: none"> 1. Low or no input voltage 2. Circuit is wired incorrectly. 3. Tees may not have been connected 4. Heater may have been severed. 5. Improper crimping of power connections causing a high resistance connection. 6. Control thermostat is wired in the opened position. 7. Pipe is at an elevated temperature. (above designed maintain) 	<ol style="list-style-type: none"> 1. Repair electrical supply lines and equipment. 2. Check to see if cables are wired correctly (series or parallel). 3. Connect and recheck the power. 4. Locate and repair the damaged heater. Recheck the power. 5. Recrimp using correct procedure. 6. Rewire in the normally closed position. 7. Check pipe temperature and recalculate the output.**
<p>D. Power output appears correct but pipe temperatures are below design value.</p>	<ol style="list-style-type: none"> 1. Insulation is wet. 2. Insufficient heater was used on valves, supports, and other heat sinks. 3. Thermostat was set incorrectly 4. Different thermal insulation was used. 5. Removable blankets 	<ol style="list-style-type: none"> 1. Remove and replace with dry insulation and insure proper weatherproofing. 2a. For a single heat sink - a separate additional cable can be installed and wired in parallel to the power connection point for the circuit. 2b. For several heat sinks - replace cable with longer cable set. 3. Reset the thermostat. 4. Check with the local or factory representatives for design conditions. Modify as recommended. 5a. Verify that K factor is equal to design. 5b. Installed properly and air gaps are sealed with duct tape.

** The power output on lower resistance heater cables is temperature sensitive and requires a special procedure to determine its value. When using 556K, 712K, 722K, 588B, 614B, 627B, 640B, 145K, 189K, or 216K heating sections, please consult factory for assistance in determining cable output.

1. Pipe No. _____	<u>DESIGN</u>	<u>ACTUAL</u>
2. Receiving Documentation - Heater Cat. No's.	_____	_____
3. Receiving Testing:	Date _____	
A. Check for physical damage.	O.K. _____	Damage _____
B. Continuity check -- check for continuity between power leads.	O.K. _____	Open _____
C. 500VDC megger check between leads and sheath, 20 megohms min.	Megohms _____	
4. Post Installation Testing:	Date _____	
A. Continuity check -- check for continuity between cold leads.	O.K. _____	Open _____
B. 500VDC megger check between leads and sheath, 20 megohms minimum.	Megohms _____	
C. Visually check cable installation prior to release for thermal insulation.	O.K. _____	Damage _____
5. Final Testing and Commissioning:	Date _____	
A. Circuit approved for testing by client.	Approved _____	
B. 500VDC megger check between leads and sheath, 20 megohms min. reading.	Megohms _____	
C. Energized Testing -- (All test data to be within 10% of design data)	<u>DESIGN</u>	<u>ACTUAL</u>
1. Circuit Voltage	_____	_____
2. Initial Current	_____	_____
3. Current after 15 minutes of operation.	_____	_____
6. Circuit Acceptance:	_____	
Date _____		

This circuit has been tested and documented in accordance with the above itemized date. This circuit approved by:

Contractor _____	Date: _____
Client _____	Date: _____

Figure 24

The **Heat Trace Installation Record** can be used to monitor the initial installation and check out process. This form can be used in conjunction with the **Periodic Inspection Record** for shown in *Figure 23*.

Nelson Heat Tracing Systems products are supplied with a limited warranty. Complete Terms and Conditions may be found on Nelson's website at www.nelsonheaters.com.

